

EPIC® SENSORS T-B-ØK / W-B-ØK
Threaded temperature sensor without neck pipe

Features

- according to DIN 43772 form 2
- temperature range -40...+250 °C
- Pt100 or thermocouple as sensing element
- Pt100 accuracy class A as standard delivery
- thermocouple accuracy class 1 as standard delivery
- AISI 316L as standard delivery material, other materials on request
- MI cable structured sensor element
- internal sensor element replaceable on the fly
- tailored solutions according to customer specific needs
- ATEX compatible Ex db version available.

Typical applications

- energy and power plant technology
- process industry
- chemical industry
- machinery and vessel construction
- manufacturing industry.

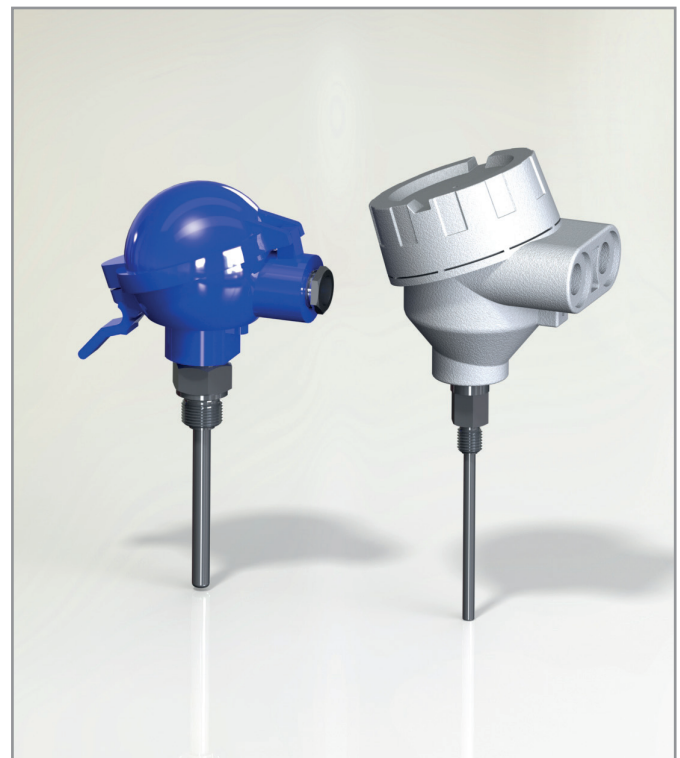

Technical data

Materials	AISI 316L, maximum temperature +250 °C, temporarily +300 °C, other materials on request
Thread	G, R, metric and NPT threads as standard delivery, other threads on request
Tolerances Pt100 (IEC 60751)	A tolerance $\pm 0.15 + 0.002 \times t$, operating temperature -100...+450 °C B tolerance $\pm 0.3 + 0.005 \times t$, operating temperature -196...+600 °C B 1/3 DIN, tolerance $\pm 1/3 \times (0.3 + 0.005 \times t)$, operating temperature -196...+600 °C B 1/10 DIN, tolerance $\pm 1/10 \times (0.3 + 0.005 \times t)$, operating temperature -196...+600 °C
Tolerances thermocouple (IEC 60584)	Type J tolerance class 1 = -40...375 °C ± 1.5 °C, 375...750 °C $\pm 0.004 \times t$ Type K and N tolerance class 1 = -40...375 °C ± 1.5 °C, 375...1000 °C $\pm 0.004 \times t$
Temperature range Pt100	-40...+250 °C
Temperature range thermocouple	-40...+250 °C
Approvals	ATEX, IECEx, EAC Ex, EAC EMC, METROLOGICAL PATTERN APPROVAL
Quality certificate	ISO 9001:2015 issued by DNV-GL
IP rating	IP65, higher IP rating on request

EPIC® SENSORS T-B-ØK / W-B-ØK
Threaded temperature sensor without neck pipe

Pt100 connections

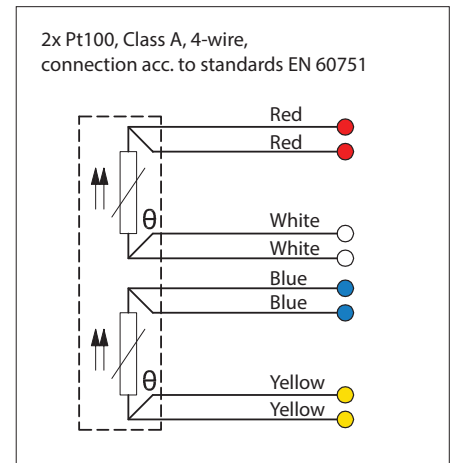
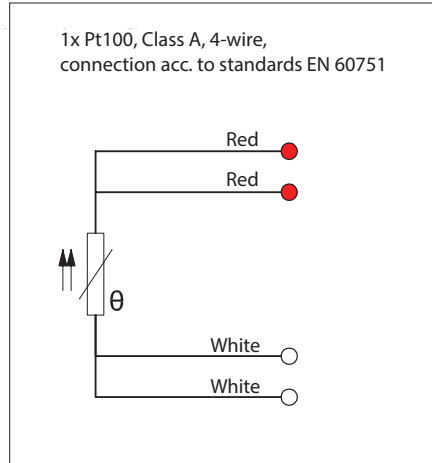
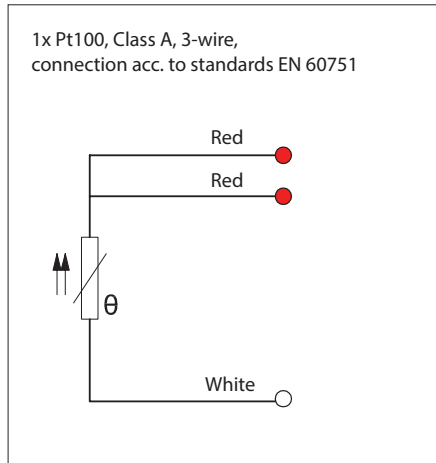

Thermoelement connections

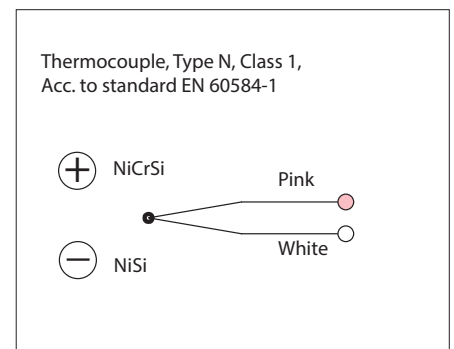
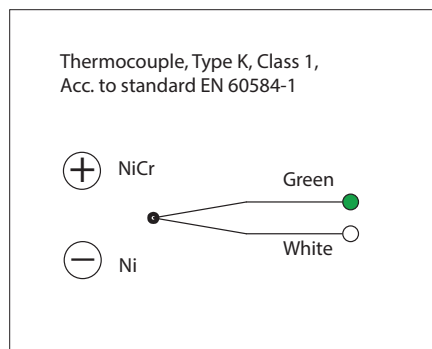
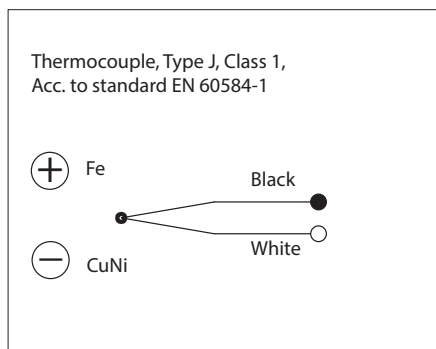

Installation examples

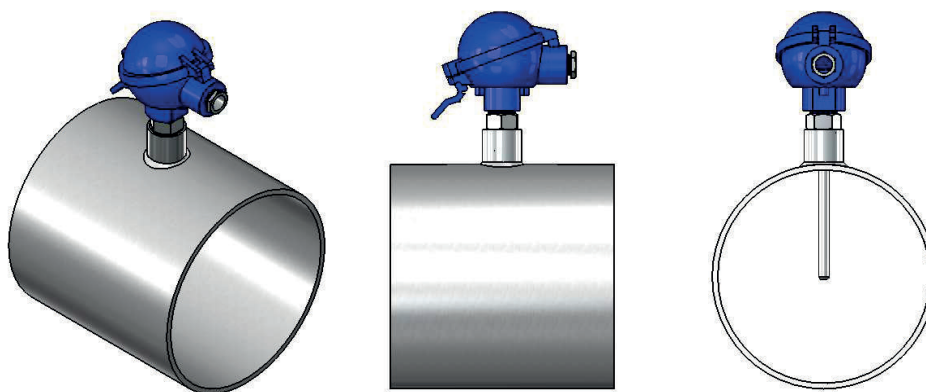

Connection heads

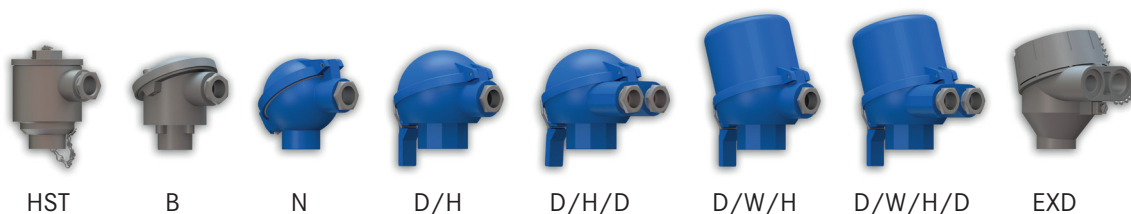

EPIC® SENSORS T-B-ØK / W-B-ØK
Threaded temperature sensor without neck pipe

Drawing

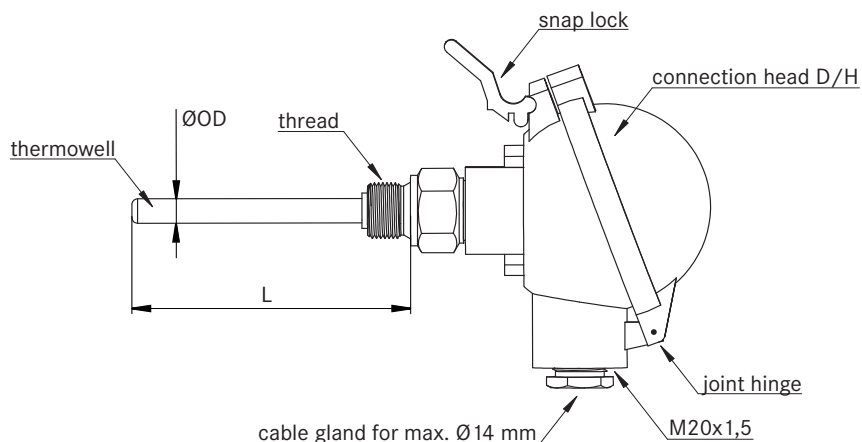

Product code key

Example code: W — B — 9K — D/H — 160 — G½" — 4 — A — TR — X

W	= Pt100 resistance thermometer
2xW	= 2 x Pt100 resistance thermometer
T	= thermocouple
2xT	= 2 x thermocouple
B	= threaded sensor type (constant in code)
6, 9, 11	= thermowell outer diameter (ØOD) [mm], other diameters on request
K	= no cooling neck (constant in code)
B	= connection head B
D/H	= connection head with snap lock
D/H/D	= connection head with snap lock and double barrel (2x cable gland)
D/W/H	= high cover connection head with snap lock
D/W/H/D	= high cover connection head with snap lock and double barrel (2x cable gland)
EXD	= ATEX compatible connection head
HST	= acid proof connection head
N	= connection head N
160	= length, L [mm]
G½"	= thread size (all available, also NPT)
4,3,2	= Pt100 wire count
K,N,J	= thermocouple type
A,B	= Pt100 accuracy class, (class A as standard delivery)
1,2,3	= thermocouple accuracy class, (class 1 as standard delivery)
TR	= wires for transmitter connection
CB	= with ceramic terminal block
X	= additional details on the text line

