

EPIC® SENSORS
Welded thermowells

Features

- according to DIN 43772 form 2F
- fitted to application with weld
- typically used with threaded temperature sensor
- threaded temperature sensor has separate cooling neck and connection head
- threaded temperature sensor has mineral insulated temperature sensor element inside, which will be sleeved with welded thermowell
- used to protect MI cable structured sensor element
- in some cases welded thermowells are referred as weld-in thermowells, product is the same
- 3D step models available on request.

Typical applications

- energy and power plant technology
- process industry
- chemical industry
- machinery and vessel construction
- manufacturing industry.

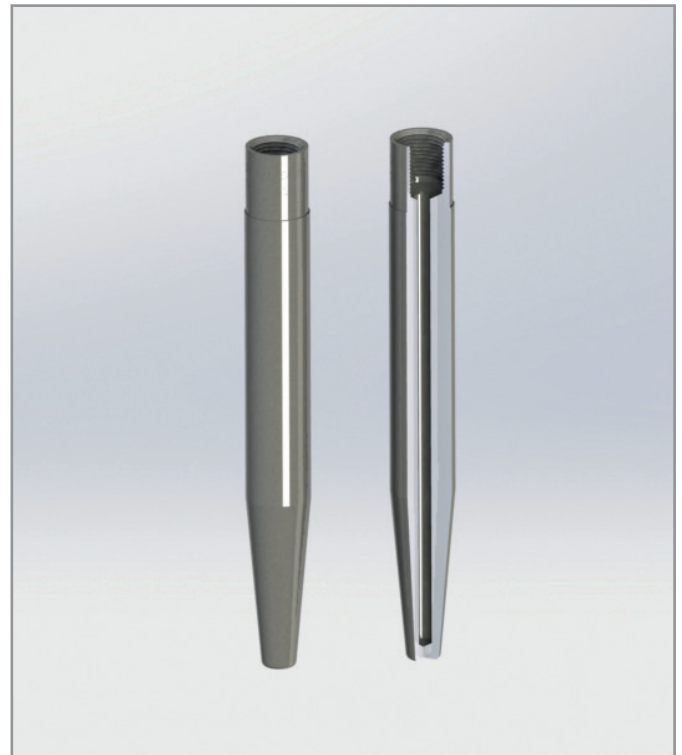

Technical data

Materials	L = 13CrMo44 / EN1.7335, max. temperature +550 °C, M = 10CrMo910 / EN1.7380, max. temperature +580 °C, O = 16Mo3 / EN1.5415, max. temperature +480 °C, K = AISI 316L / EN1.4404, max. temperature +600 °C Other materials available on request
Thread	M18x1.5 or M14x1.5, Other threads available on request
Diameter	Ø18 mm or Ø24 mm (tolerances class h7 according to ISO 286-2), Other diameters available on request
Length	140 mm, 200 mm or 260 mm, Other lengths available on request
Quality certificate	ISO 9001:2015 issued by DNV-GL

EPIC® SENSORS
Welded thermowells

Drawing

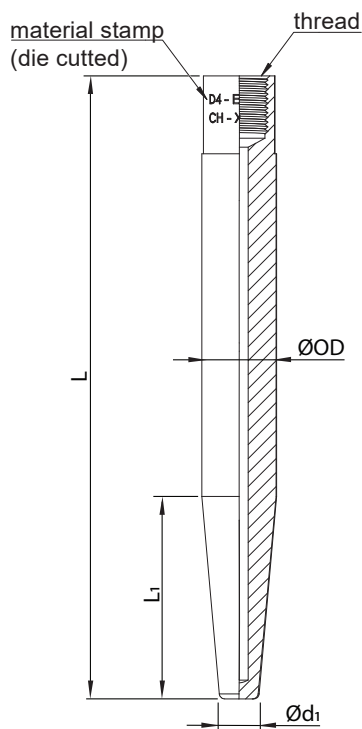

Product Code	Thermowell type	Material	L [mm]	L ₁ [mm]	$\varnothing d_1$ [mm]	$\varnothing OD$ [mm]	Tolerance (ISO 286-2)	Thread	Compatible sensor element, diameter [mm] / length [mm]
911890	D1	K - EN1.4404	140	65	12,5	24	h7	M18x1,5	6/315
911966	D1	L - EN1.7335	140	65	12,5	24	h7	M18x1,5	6/315
911907	D1	M - EN1.7380	140	65	12,5	24	h7	M18x1,5	6/315
911906	D1	O - EN1.5415	140	65	12,5	24	h7	M18x1,5	6/315
912061	D2	K - EN1.4404	200	125	12,5	24	h7	M18x1,5	6/375
912062	D2	L - EN1.7335	200	125	12,5	24	h7	M18x1,5	6/375
912063	D2	M - EN1.7380	200	125	12,5	24	h7	M18x1,5	6/375
912064	D2	O - EN1.5415	200	125	12,5	24	h7	M18x1,5	6/375
911161	D4	K - EN1.4404	200	65	12,5	24	h7	M18x1,5	6/375
911144	D4	L - EN1.7335	200	65	12,5	24	h7	M18x1,5	6/375
911165	D4	M - EN1.7380	200	65	12,5	24	h7	M18x1,5	6/375
911145	D4	O - EN1.5415	200	65	12,5	24	h7	M18x1,5	6/375
911967	D5	K - EN1.4404	260	125	12,5	24	h7	M18x1,5	6/435
911968	D5	L - EN1.7335	260	125	12,5	24	h7	M18x1,5	6/435
911457	D5	M - EN1.7380	260	125	12,5	24	h7	M18x1,5	6/435
911969	D5	O - EN1.5415	260	125	12,5	24	h7	M18x1,5	6/435
912065	D1/S	K - EN1.4404	140	65	9	18	h7	M14x1,5	3/315
912066	D1/S	L - EN1.7335	140	65	9	18	h7	M14x1,5	3/315
912067	D1/S	M - EN1.7380	140	65	9	18	h7	M14x1,5	3/315
912068	D1/S	O - EN1.5415	140	65	9	18	h7	M14x1,5	3/315
-	D2/S	K - EN1.4404	200	125	9	18	h7	M14x1,5	3/375
-	D2/S	L - EN1.7335	200	125	9	18	h7	M14x1,5	3/375
-	D2/S	M - EN1.7380	200	125	9	18	h7	M14x1,5	3/375
-	D2/S	O - EN1.5415	200	125	9	18	h7	M14x1,5	3/375
911162	D4/S	K - EN1.4404	200	65	9	18	h7	M14x1,5	3/375
911164	D4/S	L - EN1.7335	200	65	9	18	h7	M14x1,5	3/375
911166	D4/S	M - EN1.7380	200	65	9	18	h7	M14x1,5	3/375
911163	D4/S	O - EN1.5415	200	65	9	18	h7	M14x1,5	3/375
1074150	D5/S	K - EN1.4404	260	125	9	18	h7	M14x1,5	3/435
-	D5/S	L - EN1.7335	260	125	9	18	h7	M14x1,5	3/435
-	D5/S	M - EN1.7380	260	125	9	18	h7	M14x1,5	3/435
1005008	D5/S	O - EN1.5415	260	125	9	18	h7	M14x1,5	3/435

Where L = length, L₁ = tip length, $\varnothing OD$ = body diameter, $\varnothing d_1$ = tip diameter

h7 tolerance according to ISO 286-2:
for 18 mm shaft, upper limit deviation 0 mm, lower limit deviation -0.018 mm
for 24 mm shaft, upper limit deviation 0 mm, lower limit deviation -0.021 mm